

BRACKETT AIRCRAFT COMPANY INC.

www.brackettaircraft.com

BDW-206JR BELL JETRANGER MODEL 206A, B

BOX SIZE: 52" X 15" X 15"
SHIPPING WT.: 66 LBS.

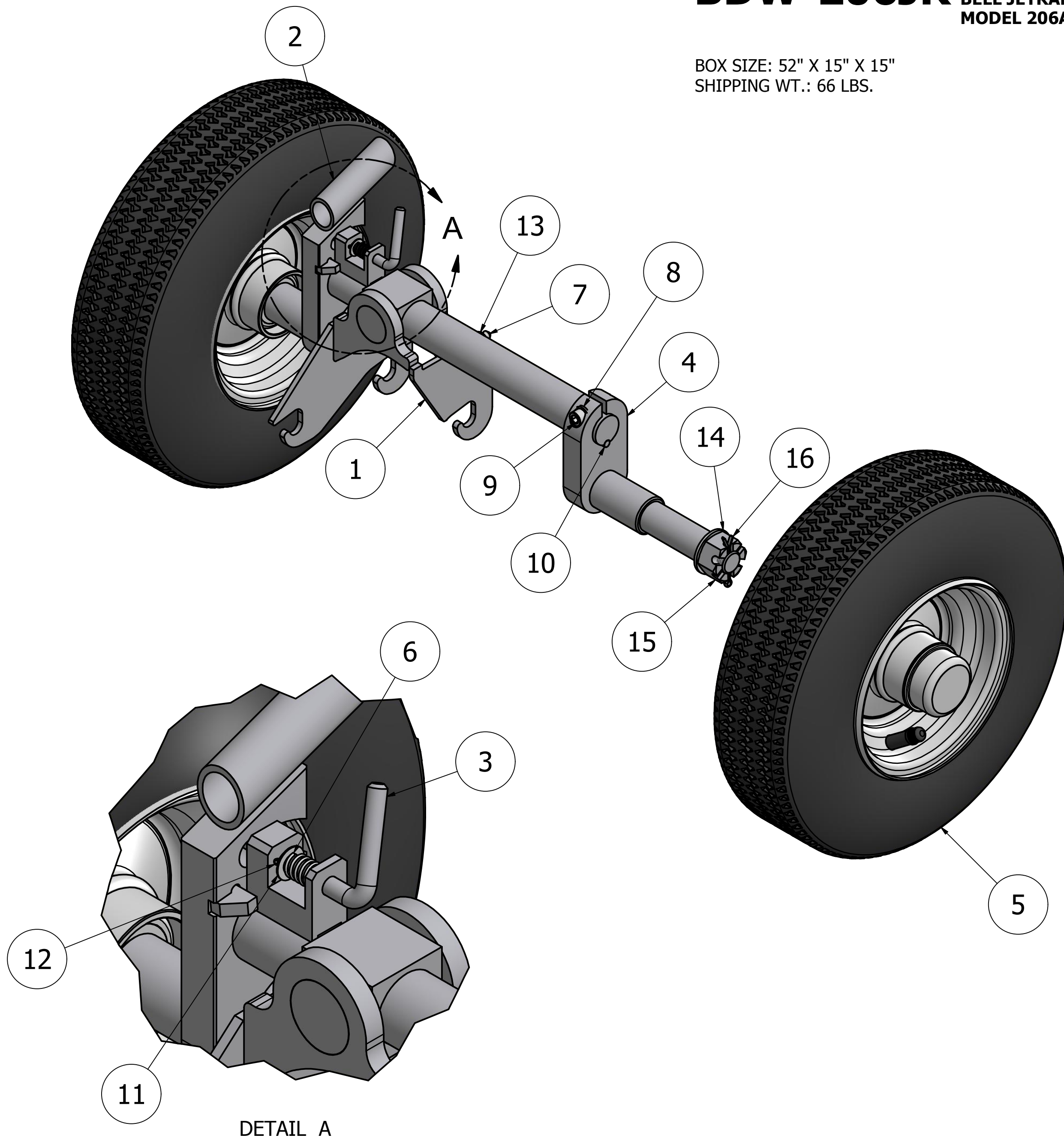

PARTS LIST

ITEM	QTY	PART NUMBER	DESCRIPTION
1	1	W-20615-10AB (W-20614-10AB RIGHT NOT SHOWN)	LEFT FRAME ASSEMBLY
2	1	W-2062-10L (W-2062-10R NOT SHOWN)	LEFT OUTER ARM
3	1	W-U-101	L-PIN
4	1	W-U-117	INNER ARM ASSEMBLY
5	2	W-41066	TIRE ASM.
6	1	S-264	SPRING
7	1	1103K31	1/8-28 ZERK FITTING
8	1	92146A030	5/16 HIGH COLLAR LOCK WASHER
9	1	91274A244	5/16-18 X 1 SOCKET HEAD CAP SCREW
10	1	98381A540	1/4 X 3/4 SOLID PIN
11	1	98017A689	5/16 THIN WASHER
12	1	92373A143	3/32 X 1/2 ROLL PIN S.S.
13	1	92146A550	1/4 LOCK WASHER
14	2	90126A036	3/4" WASHER
15	2	95030A270	3/4-16 SLOTTED HEX NUT
16	2	98338A478	1/8 X 1 1/2 COTTER PIN
17	1	W-U-110	HANDLE ASSEMBLY

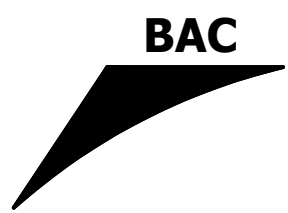

W-41066 TIRE ASM.

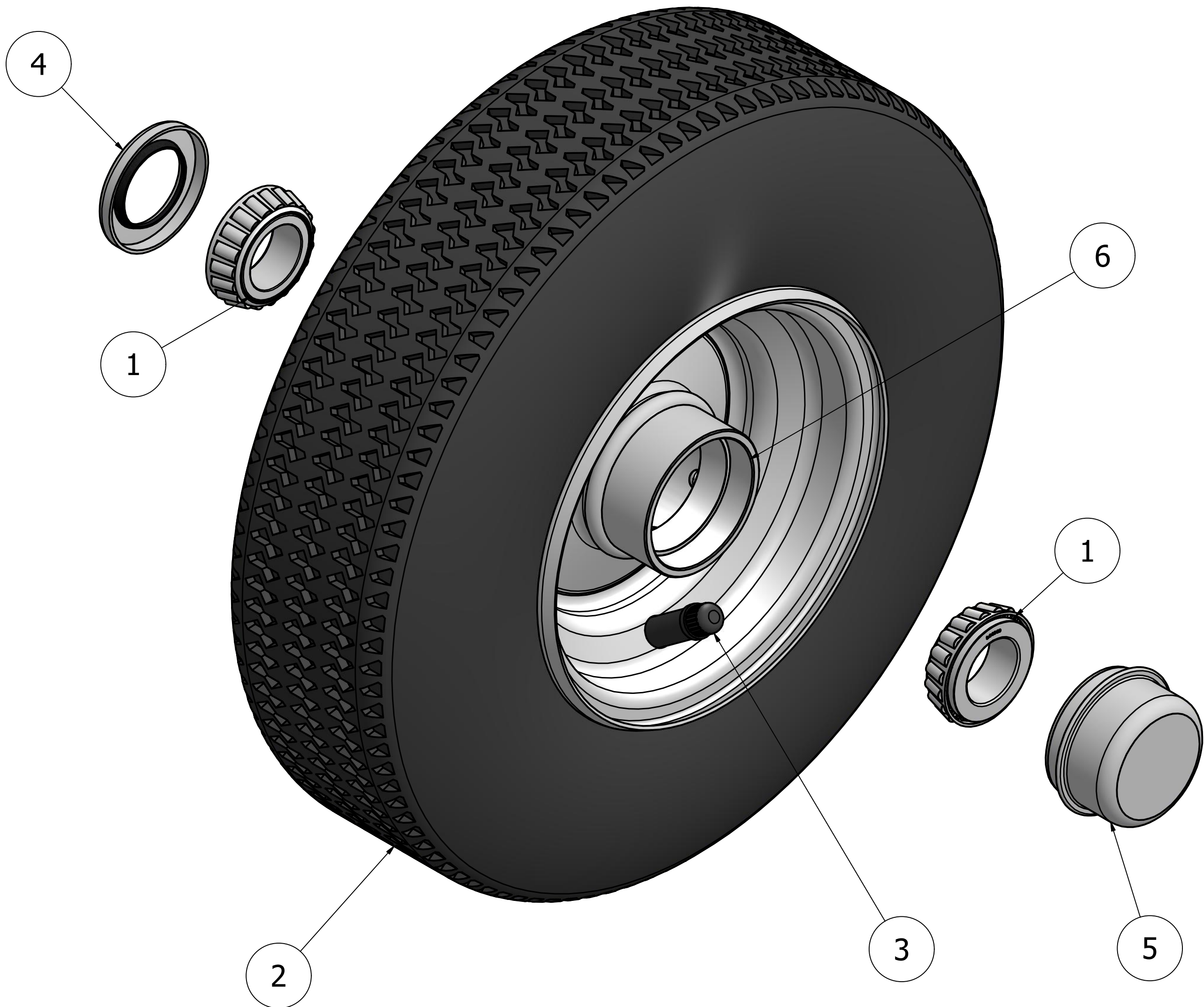

PARTS LIST

ITEM	QTY	PART NUMBER	DESCRIPTION
1	2	L44643	TAPERED ROLLER BEARING
2	1	W-41066T	W-4.10/3.50 X 6 6 PLY TIRE
3	1	W-41066TB	INNER TUBE
4	1	12192VB	GREASE SEAL
5	1	HC-1	HUB CAP
6	1	WDC6-1HS-WH	WHEEL ASSEMBLY