

Shipping Info:  
 2 boxes 26 x 13 3/4 x 13 3/4 (5.68 ft<sup>3</sup>)  
 1 tube 2 x 53" (.096 ft<sup>3</sup>)  
 Shipping Weight 72 lbs. (6.99 ft.<sup>3</sup>)

NOTE: COMPLETE ASSEMBLIES ARE SOLD IN SHIP SETS WHICH CONSIST OF BOTH THE LEFT AND THE RIGHT SIDE, PARTS ARE LISTED AS NUMBER REQUIRED PER SIDE.

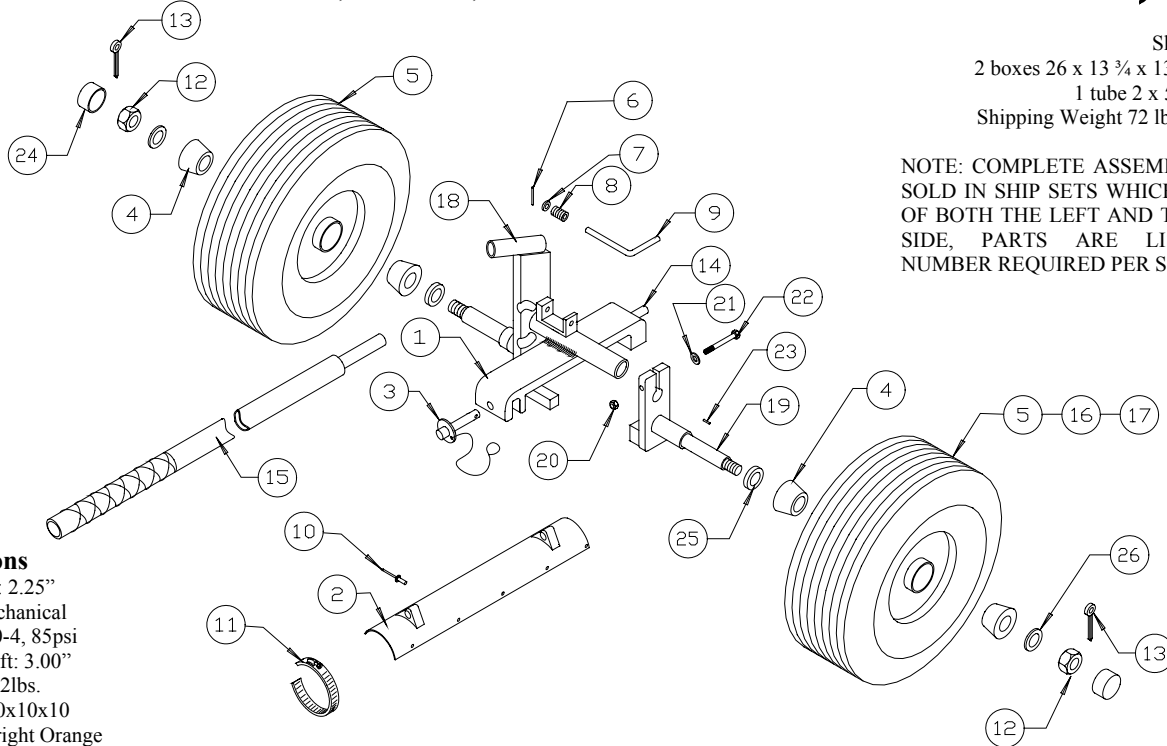

### Specifications

Skid Rube Dia: 2.25"  
 Operation: Mechanical  
 Tire Size: 4.10-4, 85psi  
 Approx. skid lift: 3.00"  
 Weight each: 22lbs.  
 Dimensions: 20x10x10  
 Paint Color: Bright Orange

Page 1 of 1

ELIGIBLE AIRCRAFT:  
 SCHWEIZER 269, 300

MODEL:  
 BDW-300

ITEM NO	PART NUMBER	DESCRIPTION	NO REQ.
1	W-300-10L; W-300-10R	Center Section	1
2	W-C300-00	Carrier	2
3	CL6BLPB1.50C	Ball Lock Pin - w/Lanyard	1
4	LM11949	Bearing	4
5	W-4.10/3.50 X 4 TW	Wheel Asm. w/Tire & Bearing	2
6	PIN ROLL 3/32 X 5/8	Roll Pin	2
7	AN960-516	Washer	1
8	S-264	Spring	1
9	W-U-101	L-Pin	1
10	NAS9301B-6-03	Blind Rivet (CR Max)	20
11	CLAMP 2 3/4	Hose Clamp	4
12	NUT SLOTTED 3/4-16	Slotted Nut	2
13	PIN COTTER 1/8 X 1 1/2	Cotter Pin	2
14	W-300-09	Nose Pin	1
15	W-U-110	Handle Assembly	1
16	W-4.10/3.50 X 4 TR	6 Ply Tire, Tubeless	2
17	W-4.10/3.50 X 4 TB	Tube	2
18	W-300-11L	Outer Arm Assembly	1
18	W-300-11R	Outer Arm Assembly	1
19	W-22A-14	Inner Arm	1
20	NUT 5/16-24	Nut	1
21	WASHER SAE 5/16	Washer	1
22	BOLT 5/16-24 X 2 1/2	Bolt	1
23	PIN ROLL 1/4 X 3/4	Roll Pin	1
24	HC-1	Hub Cap	2
25	1117844VHY	Grease Seal	2
26	WASHER SAE 3/4	SAE Washer	2
NS	W-LPK	L-Pin Kit (Items 6, 7, 8, 9)	
NS	W-LPRK	Repair Kit (W-LPK + U-100 Holder)	