

BAC

BRACKETT AIRCRAFT CO., INC.

BAC

7045 FLIGHTLINE DR.
KINGMAN, AZ 86401
928-757-4005
BRACKETTAIRCRAFT.COM



BDW-R44A

BAC

BAC

BRACKETT AIRCRAFT CO., INC.

7045 FLIGHTLINE DR.
KINGMAN, AZ 86401
928-757-4005
BRACKETTAIRCRAFT.COM

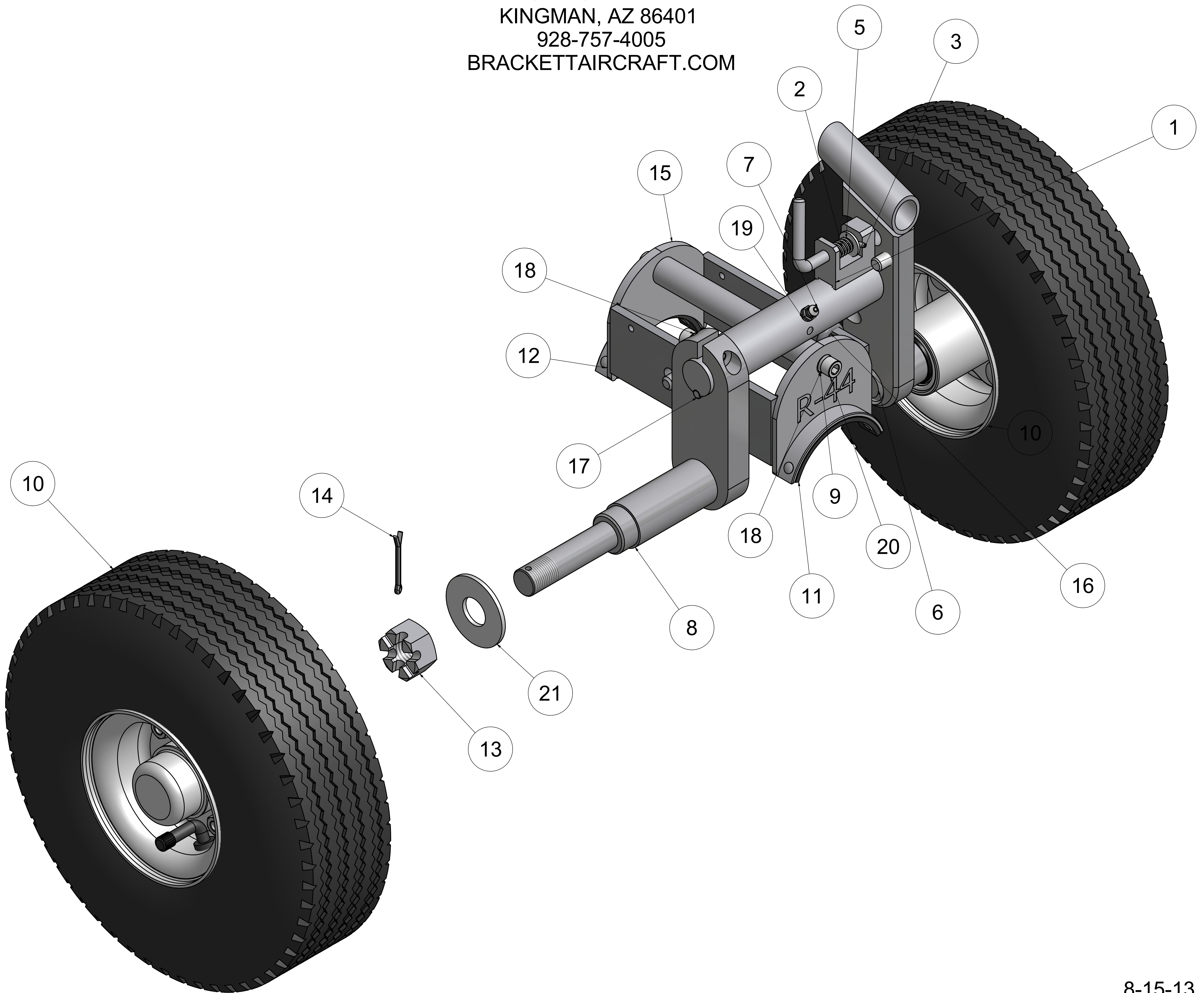

8-15-13

BDW-R44A

ITEM	QTY	PART NUMBER	DESCRIPTION
1	1	W-44-08R	
2	1	S-264	SPRING
3	1	92383A204	3/32 X 1/2 ROLL PIN S.S.
4	1	W-U-101	L-PIN
5	1	AN960-516	5/16 WASHER
6	1	W-28A-11R	OUTER ARM (RIGHT)
7	1	109SK41	1/8" ZERK FITTING
8	1	W-22A-14	INNER ARM ASM.
9	2	W-28A-05	BUSHING
10	2	W-41046	TIRE/WHEEL BOLTED ASSEMBLY
11	2	W-44-11	ROUGH BACK
12	4	97517A055	RIVET
13	2	95030A270	3/4-16 SLOTTED HEX NUT
14	2	98338A478	1/8 X 1 1/2 COTTER PIN
15	1	W-44-10	INNER FRAME ASM.
16	1	W-44-04R	PIN ASM.
17	1	98381A540	SOLID PIN
18	3	98437A112	5/16 HIGH COLLAR LOCK WASHER
19	1	98437A110	1/4 HIGH COLLAR LOCK WASHER
20	3	91274A244	SOCKET HEAD CAP SCREW
21	2	90108A036	3/4" WASHER
N.S.	1	W-U-110	CAM OVER HANDLE