

BAC

## BRACKETT AIRCRAFT CO., INC.

BAC

7045 FLIGHTLINE DR.  
KINGMAN, AZ 86401  
928-757-4005  
BRACKETTAIRCRAFT.COM

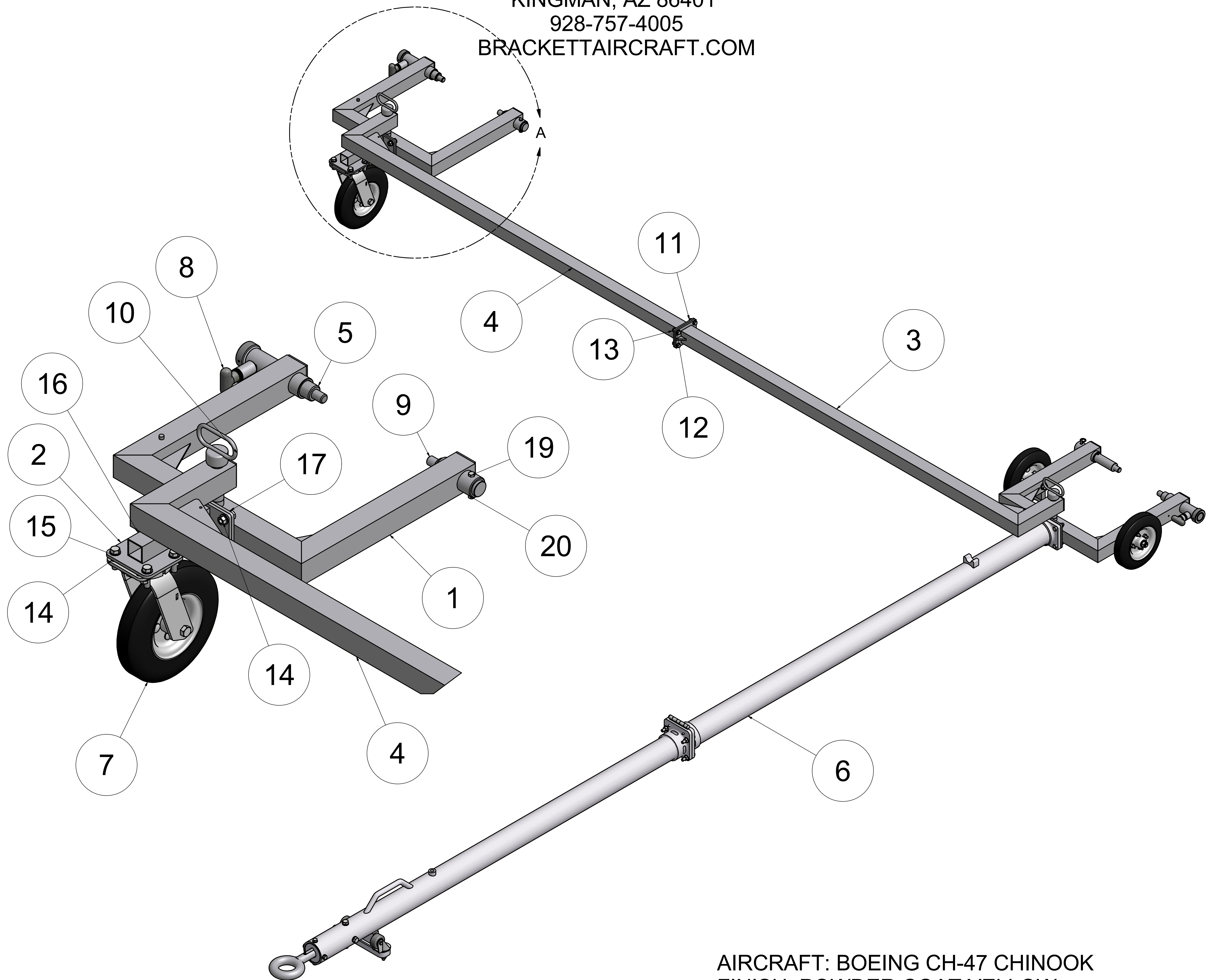

AIRCRAFT: BOEING CH-47 CHINOOK  
FINISH: POWDER COAT YELLOW  
86 X 29 X 7 @ 211 LBS.

## HT-47S

ITEM	QTY	PART NUMBER	DESCRIPTION
1	1	HT47-01-00A	YOKE ASSEMBLY
2	1	HT47-03-00	ARM ASSEMBLY
3	1	HT47-04-00	LEG ASSEMBLY
4	1	HT47-05-00	LEG ASSEMBLY
5	1	HT47-02-00	PIN ASSEMBLY
6	1	HT-647A	TOW BAR ASSEMBLY
7	1	1080-520Z	NON-LOCKING CASTER WHEEL
8	1	90222A112	LOCKING PIN ASSEMBLY
9	1	HT47-02-15	PIN
10	2	HITCH PIN 3/4	HITCH PIN
11	4	647-B-.313-24-1.00	Hex Bolt - UNC (Regular Thread - Inch)
12	8	647-W-.313-SAE	Washer A
13	4	647-LN-313-24	Hex Nut
14	8	647-LN-.375-24	Hex Nut
15	16	647-W-.375-SAE	Washer A
16	4	647-B-.375-24-1.50	Hex Bolt - UNC (Regular Thread - Inch)
17	4	647-B-.375-24-1.50	Hex Bolt - UNC (Regular Thread - Inch)
18	2	90170A650	HINGE
19	1	647-B-.250-20-2.00	Hex Bolt - UNC (Regular Thread - Inch)
20	1	647-LN-.250-20	Hex Nut