

BAC

BRACKETT AIRCRAFT CO., INC.

BAC

7045 FLIGHTLINE DR.
KINGMAN, AZ 86401
928-757-4005
BRACKETTAIRCRAFT.COM

SPECIFICATIONS
SKID TUBE DIA. 2"-3"
LENGTH
SPREAD 64"-88"
WT. 71 + 71

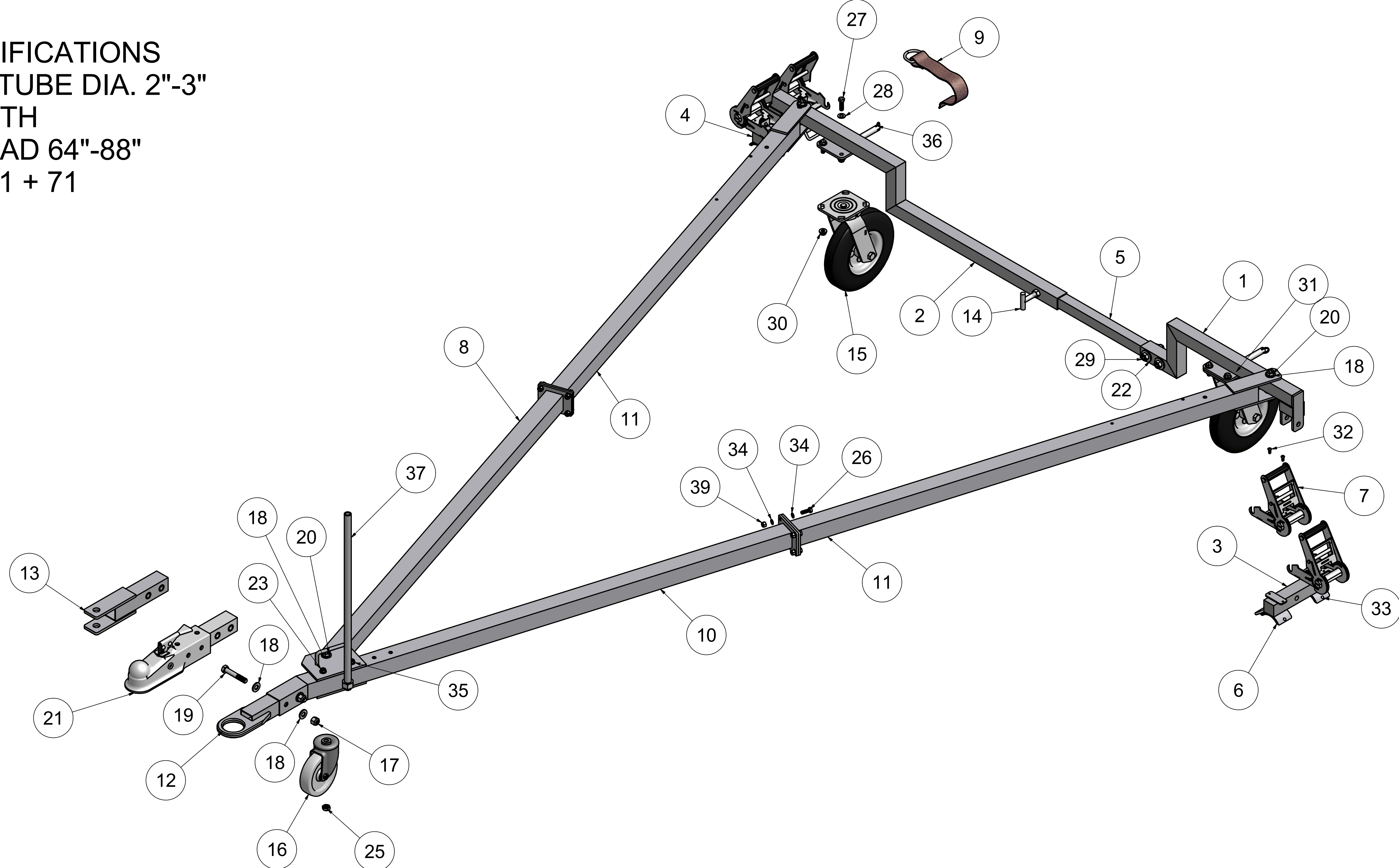

8/7/13

HT-500

ITEM	QTY	PART NUMBER	DESCRIPTION
1	1	H-4M-01-00	SPREADER ASSEMBLY L.H.
2	1	H-4M-02-00	SPREADER ASSEMBLY R.H.
3	1	H-4M-03-00L	FOOT ASM. LEFT
4	1	H-4M-03-00R	FOOT ASM. RIGHT
5	1	H-4M-04-00	SPREADER TUBE ASM.
6	4	H-6M3-00-02	ROUGH BACK
7	4	H-6M3-03-00	RATCHET ASM.
8	1	H-7M2-10	LEG ASM.
9	1	H-6M3-02-00	STRAP ASM.
10	1	H-7M8-10	YOKE ASM.
11	2	H-7M9-10	LEG ASM.
12	1	T-12-600R (HT-500R)	RING HITCH
13	1	T-12-600C (HT-500C)	CLEVIS HITCH
14	1	HT88-10-00	T HANDLE
15	2	1080-525Z	SOLID CASTER WHEEL
16	1	HM-101	CASTER WHEEL
17	6	90630A125	1/2-13 LOCKNUT
18	9	91950A033	1/2 SAE WASHER
19	2	91286A337	1/2-13 X 3 BOLT
20	3	91286A339	1/2-13 X 3 1/2 BOLT
21	1	T-12-600B	BALL HITCH
22	8	91081A033	1/2 U.S.S. WASHER
23	2	91286A171	5/16-18 X 3 BOLT
24	10	90630A115	5/16-18 LOCKNUT
25	1	94945A224	1/2-13 NYLON-INSERT THIN LOCKNUT
26	8	91286A155	BOLT 5/16-18 X 1
27	4	92865A626	3/8-16 X 1 1/4 BOLT
28	8	98180A130	3/8 WASHER
29	2	90201A429	1/2-13 X 2 1/2 BOLT
30	8	92018A430	3/8-16 HEX FLANGE LOCKNUT
31	4	91286A204	3/8-16 X 1 1/2 BOLT
32	8	90272A829	10-32 X 1/2 BHS
33	8	97517A055	1/8 X 1/2 RIVET
34	16	AN960-516L	5/16 NARROW WASHER
35	4	98180A120	5/16 WASHER
36	2	1080-525-SL	CASTER WHEEL LOCK
37	1	TY-TB-125-10-00	HANDLE