

BRACKETT AIRCRAFT COMPANY INC.

www.brackettaircraft.com

HT-7M UNIVERSAL HELICOPTER TOW BAR

AVAILABLE WITH A RING, BALL OR CLEVIS HITCH

APPLICABLE AIRCRAFT: HELICOPTERS WITH SKID TUBE DIAMETERS 2" TO 4"
 SHIPPING SPECS.: 30" X 15" X 19" @ 73 LBS. + 72" X 9" X 9" @ 72 LBS.
 FINISH: POWDER COAT ORANGE

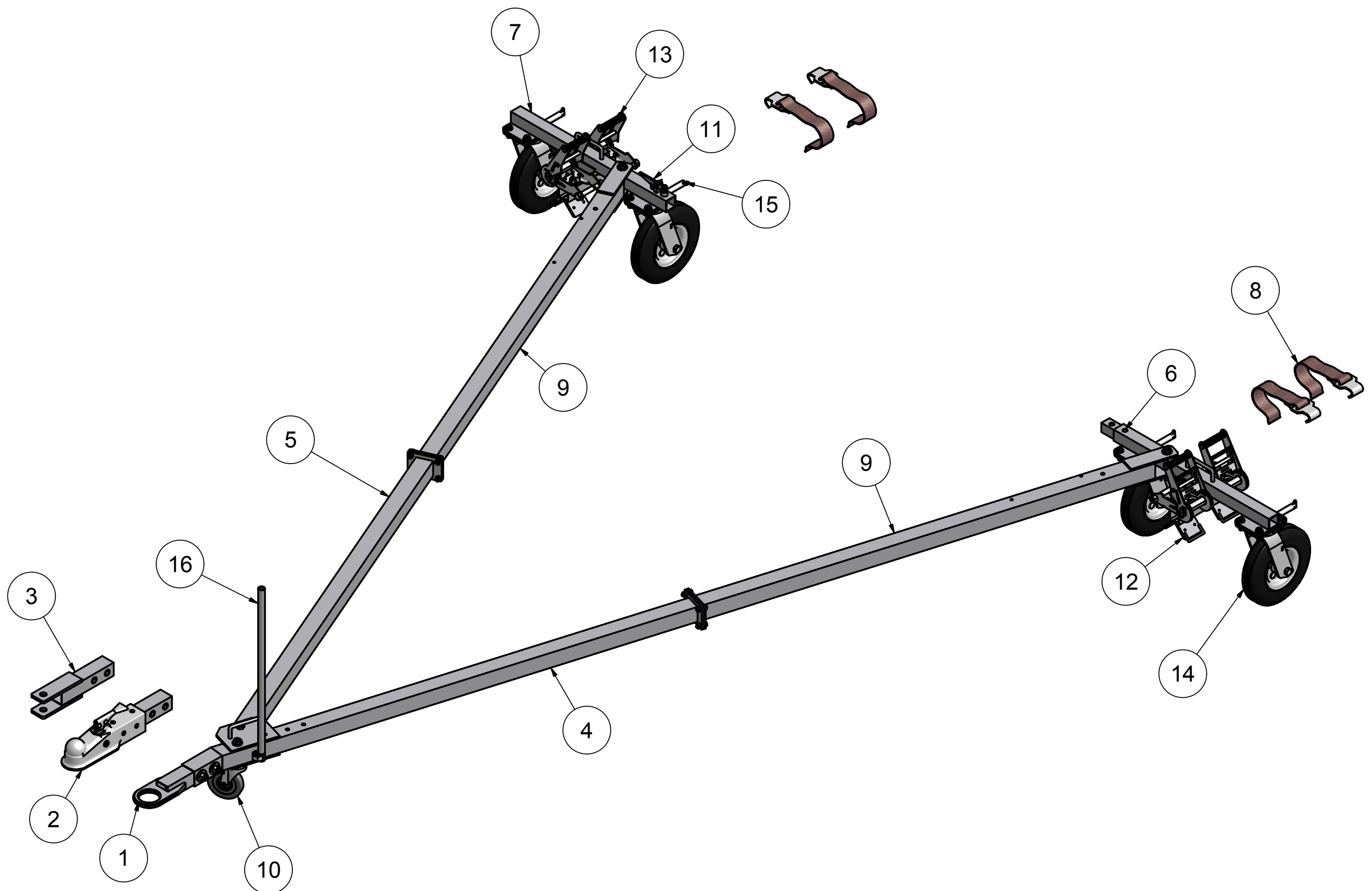

1080-520Z CASTER WHEELS UPDATED SERIAL # 1159 AND ABOVE.

PARTS LIST

ITEM	QTY	PART NUMBER	DESCRIPTION
1	1	T-12-600R (HT-7MR OPTION)	RING HITCH
2	1	T-12-600B (HT-7MB OPTION)	BALL HITCH
3	1	T-12-600C (HT-7MC OPTION)	CLEVIS HITCH
4	1	H-7M8-10	YOKE ASM.
5	1	H-7M2-10	LEG ASM.
6	1	H-7M3-00LA	LEFT FOOT ASM.
7	1	H-7M3-00RA	RIGHT FOOT ASM.
8	4	H-7M4-00	STRAP ASM.
9	2	H-7M9-10	LEG ASM.
10	1	HM-101	CASTER WHEEL
11	1	T-103	LEVER ASSEMBLY
12	4	H-7M6-00A	ANGLE CUP ROUGH BACK
13	4	H-7M5-00	RATCHET ASSEMBLY
14	4	1080-525Z	SOLID CASTER WHEEL
15	4	1080-525-SL	CASTER WHEEL LOCK
16	1	TY-TB-125-10-00	HANDLE